

Performance and Emission of Diesel Engine Fuelled with Water-in-Diesel Emulsion

Open
Access

Shunsuke Watanabe¹, Ahmad Muhsin Ithnin^{2,*}, Hasannuddin Abdul Kadir², Muhd Aiman Abu Bakar², Wira Jazair Yahya²

¹ Meiji University, 1 Chome-1 Kanda Surugadai, Chiyoda, Tokyo 101-8301, Japan

² Malaysia – Japan International Institute of Technology (MJIIT), University Teknologi Malaysia Kuala Lumpur, Jalan Sultan Yahya Petra (Jalan Semarak), 54100 Kuala Lumpur, Malaysia

ARTICLE INFO

Article history:

Received 5 April 2017

Received in revised form 16 May 2017

Accepted 21 July 2017

Available online 13 September 2017

ABSTRACT

Power generation using combustion engine cause severe air pollution. Research for a high efficient engine with less harmful emission is highly demanded. Water-in-Diesel (W/D) emulsion has a potential to reduce fuel consumption and harmful exhaust emission, especially nitrogen oxides (NOx) and particulate matter (PM). Experimental study was conducted by operating single cylinder MR MARK MC-D6500E diesel generator at different loading conditions while using two types of W/D emulsion containing different water contents (10 and 20 vol.%) with 1 vol.% of surfactant (span 80) as additive to stabilize the fuel. The effect of water on fuel consumption, exhaust temperature and emission has been studied and the results have been compared to conventional diesel fuel. The result showed NOx and PM were reduced up to 51% and 14% respectively by using W/D emulsion. Fuel consumption also was up to 10% improved by using W/D emulsion.

Keywords:

Diesel engine, emulsion, particulate matter, nitrogen oxides

Copyright © 2017 PENERBIT AKADEMIA BARU - All rights reserved

1. Introduction

The world is currently facing environmental problems such as exhaustion of petroleum, global warming, climate change and air pollution. It is inevitable to start reducing fuel consumption and emission gas.

Compression ignition engine, which is diesel engine, has the highest efficiency compared to other internal combustion engines. However, diesel engine generates a lot more undesirable emissions such as nitrogen oxides (NOx) and particulate matter (PM) during combustion [1]. The emissions have a bad impact not only on our health but also our ecosystem. It is proven to trigger fatal illnesses such as lung cancer, asthma, and cardiovascular issues [2].

The reduction of both NOx and PM are normally cannot be achieved due to the contradictory mechanism of their formation in the combustion chamber of a diesel engine. The reduction of NOx is achieved by a low combustion flame temperature. On the other hand, PM can be reduced by

* Corresponding author.

E-mail address: ahmadmuhsin@utm.my (Ahmad Muhsin Ithnin)

inhibiting their formation through better mixing of the fuel and improving their oxidation by increasing the combustion temperature. Thus, the balance between NOX and PM must be considered in trying to reduce those emissions simultaneously [3].

Diesel oxidation catalysts (DOCs) and diesel particulate filters (DPFs) is currently used to mitigate PM as an after treatment system. DOCs have potential to reduce the PM by up to 25% and they are widely used due to relatively cheaper than its rivals or alternatives, as well as being robust. DPFs on the other hand, can reduce PM by up to 90%. However, they can only be used under higher engine exhaust temperatures with low sulphur oil. Additionally, their costs are three times more expensive than DOCs [4].

The introduction of water into diesel engine is a method that can reduce the formation of NOX and PM emissions simultaneously [5,6]. There are three common methods to introduce water into the diesel engine: [7-9]; spraying water into the intake manifold which is called the intake manifold fumigation [7-9]; water injection into the combustion chamber which is called direct water injection method [10,11]; and Water-in-Diesel (W/D) emulsion. All of the methods can reduce both NOX and PM simultaneously. However, intake manifold fumigation and direct water injection tends to be in direct contact with the fuel feed system and cylinder piston group when the water is introduced into the combustion chamber, thus leading to oil contamination and increasing wear [12]. In addition, both methods require essential modification to the engine in order to integrate the water addition device onto it. Thus, it requires high additional cost [13].

W/D emulsion is the promising alternative fuel that can reduce NOX and PM emission simultaneously while at the same time improves combustion efficiency. This is due to micro explosion phenomena which is a special occurrence that intrigues researchers worldwide as it is nonexistent in the normal diesel combustion process in a diesel engine. Micro explosion is the secondary atomization after the initial spray because of the rapid evaporation process of water that is initially contained in an oil drop [14], tearing up the droplet into very fine particles, more surface area of the fine droplets can be exposed to the air leading to an improvement in the fuel and air mixing process. As a result, the combustion efficiency will increase [15]. In addition to reduce the harmful emissions, emulsion can be utilized without any modification [16]. W/D emulsion is a mixture of two immiscible liquid that consists of water and diesel fuel. W/D emulsion is formed with the help of mechanical agitation together with the chemical additives so called surfactant to keep the immiscible liquids being tied together forming one solution.

The objective of this research is to evaluate the W/D emulsion at two different water concentrations using single cylinder diesel engine generator and determine the engine performance and exhaust emission.

2. Experimental Setup

A four stroke single cylinder engine was employed in the experiment. The combustion system of the engine is toroidal crown and intake port type is helical. The other specifications of the engine are shown in Table I . The schematic of engine testing setup is shown in Figure 1, which consists of emission analyser, voltage regulator, and mini-dilution tunnel. Mini-Dilution tunnel was employed for sampling particular emissions. Exhaust gas was diluted by clean air that was heated up to 50°C at dilution rate of 10. Dilution ratio was controlled by the amount of CO₂ between inside exhaust gas and inside dilution channel. CO₂ was measured with nondispersive infrared analyser NDIR (HORIBA VIA-510). This diluted gas was absorbed with uniform velocity by diaphragm pump, and particulate was trapped with Teflon filter (MILLIPORE FHLPO4700, diameter 47mm, orifice 0.47 μm). The testing method is based on the SAE standard for engine testing as the guideline [17]. The engine generator

is loaded by spotlight lamp from 1 kW up to 5 kW respectively which is controlled by a voltage regulator. Exhaust gases emission which is carbon monoxide (CO) and nitrogen oxides (NOX) are measured by TESTO 350 emission analyser. The analyser is equipped inside the exhaust tail pipe of the engine. Table II shows the specification of the formation of emulsion fuel. Span 80 is used as emulsifier to stabilize emulsion fuel. Abdul Kadir H et al [18] concluded that Span 80 is the most effective surfactant while the optimum mixing condition to produce W/D emulsion fuels is approximately 5 minutes with the mixing speed of 2500rpm.

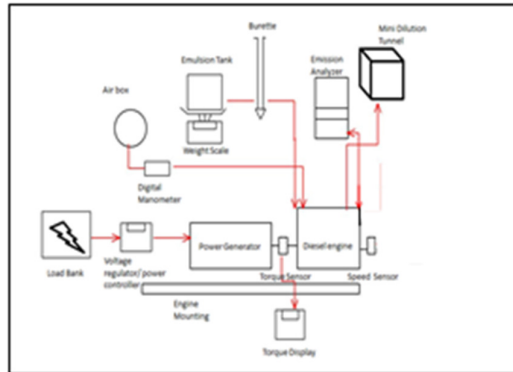

Fig. 1. The schematic of engine testing setup

Table 1

Engine Specifications

Engine type	MR MARK MC-D6500E 4-stroke, single cylinder, air-cooled, direct injection diesel engine
Continuous Power [kW]	5.0
Max. Power [kW]	5.5
Bore x Stroke [mm]	86 x72
Displacement [L]	0.418
Rated Revolution [RPM]	3000

Table 2

Fuel Specifications

Fuel	Diesel [%]	Water [%]	Surfactant (span 80) [%]	Mixing time [min]	Mixing speed [rpm]
Diesel	100	0	0	0	0
E 10	89	10	1	5	2500
E 20	79	20	1	5	2500

3. Experimental Results and Discussion

This study has attempted to use W/D emulsion with higher percentage of water content such as 30% and 40%. However, W/D emulsion with water content higher than 20% gives unstable running condition of diesel engine due to misfiring. Therefore, only W/D emulsion with 10% and 20% water content have been used in this experiment.

Figure 2 shows the amount of PM with load using different fuel. From the graph, PM is approximately reduced from 6.5% up to 14% by using W/D emulsion. Additionally, as the percentage of water in W/D

emulsion increases, the amount of emitted PM decreases. The formation of PM is reduced when using W/D emulsion due to the increase of OH radical with the addition of water [19]. Others considered the occurrence of micro-explosions for water droplets of this small size and attributed the soot reduction to heat extraction by the droplets, decreasing the rate of pyrolysis reactions, and to the enhanced oxidation of soot by the additional OH radicals [14].

Figure 3 shows the exhaust temperature using different fuel at different load conditions. The results show the exhaust temperature to be decreasing when the percentage of water in the emulsion increases. The decrease in exhaust gas is caused by heat sink phenomenon. The phenomenon is caused by dispersed water droplets due to rapid evaporation of water. When heat sink occurs, it results in the water inner phase partially absorbing the calorific heat value of the emulsions, thereby decreasing the burning gas temperature [20].

Figure 4 shows the amount of emitted CO using different fuel. The formation of CO emission is increased when using W/D emulsion. This is due to the lower combustion temperature [21] and the high amount of OH radical from the water that promotes oxidation of carbon to CO [22]. The gap for the amount of CO between E-10 and E-20 shrinks at high load. This may be due to oxidation of carbon to CO that declined with the increasing exhaust temperature at high load.

Figure 5 shows the amount of emitted NO_x using different fuel. From the graph, the NO_x for emulsion fuels are reduced from 10% up to 51% in comparison with conventional diesel fuel. NO_x using E-20 shows more reduction than E-10 at all load conditions. This is because vaporized water reduces the flame temperature as shown Fig. 3. The lower combustion temperature for emulsion inhibit the reduction of NO_x [3]. Others conclude the reduction of NO_x occurs in order to change the chemical composition of the reactants, resulting in higher OH radical concentration controlling the NO formation rate [23].

Figure 6 shows fuel consumption with load and the consuming mass was calculated including water. Fuel consumption of emulsion fuels is higher than conventional diesel at all load condition. This is because the calorific value of emulsion is lower than conventional diesel. Fuel consumption for emulsion fuel is increased due to the scarcity of heat value.

Figure 7 shows the comparison of fuel consumption using different fuels and the consuming mass was considered without water. The graph shows that fuel consumption for diesel fuel is slightly higher than the consumption for emulsion fuels. The reduction in fuel consumption may be caused by the following 7 factors: micro-explosion phenomena, improved air-entraining in the spray due to the increased spray momentum, bigger premixed combustion due to ignition delay, increase in excess of air ratio due to the presence of water in the fuel, reduction in combustion temperature due to the reduction of cooling loss, suppression of thermal dissociation as a result from the reduction of combustion temperature, and more product of combustion gas due to presence of water in the emulsion [12,21,24-26].

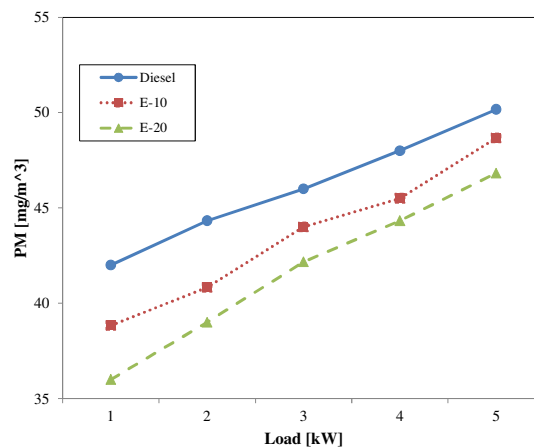

Fig. 2. PM measurement for different fuel at varying load conditions

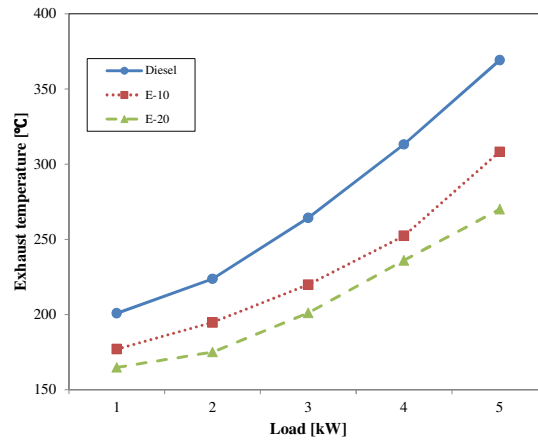

Fig. 3. Exhaust temperature for different fuel at varying load conditions

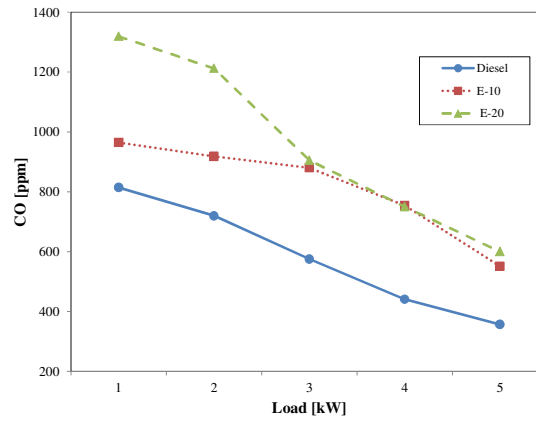

Fig. 4. The amount of CO for different fuel at varying load conditions

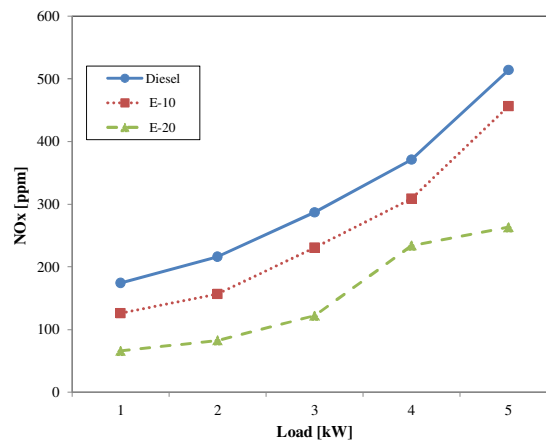

Fig. 5. The amount of NOx measurement for different fuel at varying load conditions

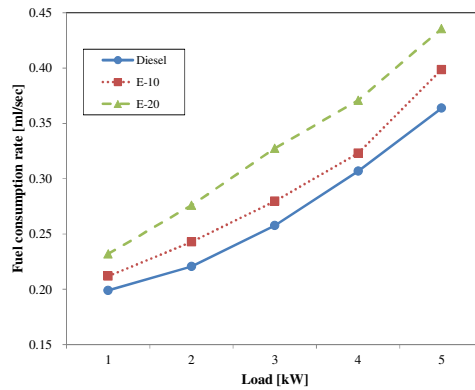

Fig. 6. Fuel consumption for different fuel at varying load conditions by considering the diesel and water as total fuel

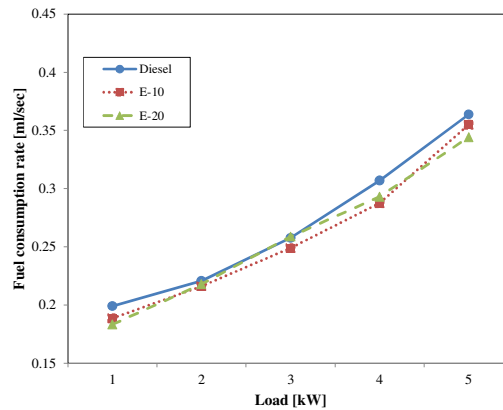

Fig. 7. Fuel consumption for different fuel at varying load conditions by considering the diesel as total

4. Conclusions

Higher water content up to 20 vol.% in W/D emulsion give greater reduction of NOx and PM. Additionally, fuel consumption is also slightly decreased when W/D emulsion is used. On the other hand, higher water content in W/D fuel leads to increase CO. There is less research to investigate the effect of engine performance and emission using W/D fuel in long term operation and this will be an interesting topic to be explored in the future.

References

- [1] Kumar, M. Senthil, Jérôme Bellettre, and Mohand Tazerout. "The use of biofuel emulsions as fuel for diesel engines: a review." (2009): 729-742.
- [2] Ithnin, Ahmad Muhsin, Hirofumi Noge, Hasannuddin Abdul Kadir, and Wira Jazair. "An overview of utilizing water-in-diesel emulsion fuel in diesel engine and its potential research study." *Journal of the Energy Institute* 87, no. 4 (2014): 273-288.
- [3] Ghojel, Jamil, Damon Honnery, and Khaled Al-Khaleefi. "Performance, emissions and heat release characteristics of direct injection diesel engine operating on diesel oil emulsion." *Applied Thermal Engineering* 26, no. 17-18 (2006): 2132-2141.

- [4] Nadeem, M., Chalillullah Rangkuti, K. Anuar, M. R. U. Haq, I. B. Tan, and S. S. Shah. "Diesel engine performance and emission evaluation using emulsified fuels stabilized by conventional and gemini surfactants." *Fuel* 85, no. 14-15 (2006): 2111-2119.
- [5] Bertola, Andrea, Renxian Li, and Konstantinos Boulouchos. *Influence of water-diesel fuel emulsions and EGR on combustion and exhaust emissions of heavy duty DI-diesel engines equipped with common-rail injection system*. No. 2003-01-3146. SAE Technical Paper, 2003.
- [6] Selim, Mohamed YE, and Mamdouh T. Ghannam. *Performance and engine roughness of a diesel engine running on stabilized water diesel emulsion*. No. 2007-24-0132. SAE Technical Paper, 2007.
- [7] Nazha, Marouan AA, Hobina Rajakaruna, and S. A. Wagstaff. *The use of emulsion, water induction and EGR for controlling diesel engine emissions*. No. 2001-01-1941. SAE Technical Paper, 2001.
- [8] Udayakumar, R., S. Sundaram, and R. Sriram. *Reduction of NOx emissions by water injection in to the inlet manifold of a DI diesel engine*. No. 2003-01-0264. SAE Technical Paper, 2003.
- [9] Tauzia, Xavier, Alain Maiboom, and Samiur Rahman Shah. "Experimental study of inlet manifold water injection on combustion and emissions of an automotive direct injection diesel engine." *Energy* 35, no. 9 (2010): 3628-3639.
- [10] Bedford, Fritz, Chris Rutland, Peter Dittrich, Alois Raab, and F. Wirbeleit. *Effects of direct water injection on DI diesel engine combustion*. No. 2000-01-2938. SAE Technical Paper, 2000.
- [11] Psota, M. A., W. L. Easley, T. H. Fort, and A. M. Mellor. *Water injection effects on NOx emissions for engines utilizing diffusion flame combustion*. No. 971657. SAE Technical Paper, 1997.
- [12] Yang, W. M., H. An, S. K. Chou, K. J. Chua, B. Mohan, V. Sivasankaralingam, V. Raman, A. Maghbouli, and J. Li. "Impact of emulsion fuel with nano-organic additives on the performance of diesel engine." *Applied energy* 112 (2013): 1206-1212.
- [13] Kumar, M. Senthil, J. Bellettre, and M. Tazerout. *Investigations on a CI engine using animal fat and its emulsions with water and methanol as fuel*. No. 2005-01-1729. SAE Technical Paper, 2005.
- [14] Ballester, Javier M., Norberto Fueyo, and Cesar Dopazo. "Combustion characteristics of heavy oil-water emulsions." *Fuel* 75, no. 6 (1996): 695-705.
- [15] Ocampo-Barrera, Rene, Rafael Villaseñor, and Antonio Diego-Marin. "An experimental study of the effect of water content on combustion of heavy fuel oil/water emulsion droplets." *Combustion and flame* 126, no. 4 (2001): 1845-1855.
- [16] Hagos, Ftwi Y., A. Rashid A. Aziz, and Isa M. Tan. "Water-in-diesel emulsion and its micro-explosion phenomenon-review." In *Communication Software and Networks (ICCSN), 2011 IEEE 3rd International Conference on*, pp. 314-318. IEEE, 2011.
- [17] Engine Power Test Code—Spark Ignition and Compression Ignition—Net Power Rating. SAE Int Surf Veh Stand 2004;SAE J1349.
- [18] Hasannuddin, A. K., M. I. Ahmad, M. Zahari, S. S. Mohd, A. B. Aiman, S. A. Aizam, and J. Y. Wira. "Stability Studies of Water-in-Diesel Emulsion." In *Applied Mechanics and Materials*, vol. 663, pp. 54-57. Trans Tech Publications, 2014.
- [19] Kadota, T., and H. Yamasaki. "Recent advances in the combustion of water fuel emulsion." *Progress in energy and combustion science* 28, no. 5 (2002): 385-404.
- [20] Lin, Chong-Yuan, and Kuo-Hua Wang. "Diesel engine performance and emission characteristics using three-phase emulsions as fuel." *Fuel* 83, no. 4-5 (2004): 537-545.
- [21] Cui, Xiaoqi, Arjan Helmantel, Valeri Golovichev, and Ingemar Denbratt. *Combustion and emissions in a light-duty diesel engine using diesel-water emulsion and diesel-ethanol blends*. No. 2009-01-2695. SAE Technical Paper, 2009.
- [22] Koc, A. Bulent, and Mudhafar Abdullah. "Performance and NOx emissions of a diesel engine fueled with biodiesel-diesel-water nanoemulsions." *Fuel Processing Technology* 109 (2013): 70-77.
- [23] Samec, Niko, Breda Kegl, and Robert W. Dibble. "Numerical and experimental study of water/oil emulsified fuel combustion in a diesel engine." *Fuel* 81, no. 16 (2002): 2035-2044.
- [24] Subramanian, K. A., and A. Ramesh. *Experimental investigation on the use of water diesel emulsion with oxygen enriched air in a DI diesel engine*. No. 2001-01-0205. SAE Technical Paper, 2001.
- [25] Alahmer, A., J. Yamin, A. Sakhrieh, and M. A. Hamdan. "Engine performance using emulsified diesel fuel." *Energy Conversion and Management* 51, no. 8 (2010): 1708-1713.
- [26] Fahd, M. Ebna Alam, Yang Wenming, P. S. Lee, S. K. Chou, and Christopher R. Yap. "Experimental investigation of the performance and emission characteristics of direct injection diesel engine by water emulsion diesel under varying engine load condition." *Applied Energy* 102 (2013): 1042-1049.