

Failure of steel helical gear used for automotive transmission

Open
Access

Ahmad Syafiq Asyraf Ahmad Sabri¹, Zainudin A. Rasid^{1,*}, Mohamad Zaki Hassan²

¹ Department of Mechanical Precision Engineering, Malaysia Japan International Institute of Technology, Jalan Sultan Yahya Petra, 54100 Kuala Lumpur, Malaysia

² Department of Engineering, Razak School of Engineering & Advanced Technology, Jalan Sultan Yahya Petra, 54100 Kuala Lumpur, Malaysia

ARTICLE INFO

Article history:

Received 27 July 2017

Received in revised form 10 October 2017

Accepted 13 October 2017

Available online 17 October 2017

Keywords:

Helical gear, AGMA formulation, bending stress, pitting stress, finite element method

ABSTRACT

The advantage of helical gear that can operate silently, on parallel and non-parallel shafts at high capacity has been great such that helical gears are used in almost all car transmission systems. As such, study on two major failures of helical gears which are due to bending and contact stresses is critical. In this research, modelling of a helical gear that is used in a 5-speed transmission car system has been conducted using finite element method. Bending and pitting stress analysis have been conducted on this helical gear that was modelled in 3D involute form. The obtained results of maximum bending and contact stresses have been compared to analytical results obtained using the American Gear Manufacturing Association (AGMA) formulations. The results of the FEM modelling and the AGMA formulations have been found to be in good agreement. Furthermore, parametric studies have been conducted on the effects of face width and helical angle of the gears on the bending and pitting stresses. It is observed that the increase of face width of the gear will decrease the maximum bending stress while the increase of the helical angle will increase the pitting stress in a non-linear fashion for both cases.

Copyright © 2017 PENERBIT AKADEMIA BARU - All rights reserved

1. Introduction

Gear is one of the most important components in mechanical power transmission system. The forces transmitted between meshing gears supply torsional moments to shafts for motion, power transmission and create forces and moments that affect the shaft and its bearings. Furthermore, compared to other power transmission machine elements such as belt and chain, gear will remain as the ultimate critical machine element for transmitting power in future machines due to its very high degree of compactness, efficiency and reliability. Nowadays, the accelerated growth of industries such as automobile, aircraft and machinery requires the industries to be ahead in position and innovation especially through the utilization of gear technology. As an example, in the automobile

* Corresponding author.

E-mail address: arzainudin.kl@utm.my (Zainudin A. Rasid)

sector which is one of the biggest users of gear, the design of light weight and highly dependable gears that are free from gear failures is just essential [1]. Two important static gear failures are due to bending and contact stresses while high vibration and noise level are the concerns in the case of dynamic analysis. The analytical approach in determining the bending stress has been based on the Lewis' equation that assumes gear tooth behaves as a cantilever beam while the determination of the contact stress is based on the Hertz's contact formula. In standard industrial practice, both stresses are determined using the AGMA formulations which have been developed based on the Lewis' formula for bending stress and the Hertz's formula for contact stress while embedding several empirical based parameters in those formulas [2]. Inevitably, the design of gears using this analytical and empirical formulation requires a large number of iterations and data sets before correct design data can be determined. As such in today's industries, finite element method (FEM) that produces quicker results at cheaper cost when conducting these iterations has been the preferred alternative to designers.

Ramamurthi *et al.* [3] conducted three-dimensional static and dynamic analysis of spur and bevel gear teeth using FEM. The computationally efficient approach of cyclic symmetry concept is applied while treating each tooth as a repeatable substructure or a rotationally periodic structure instead of applying fixed boundary condition and treating one tooth to be isolated to other teeth. The total displacement was the addition of displacements due to each Fourier harmonic component of the contact line force. A comparison study of bending stresses for different face width of 15 numbers of helical gears was conducted by Mishra and Murthy [4]. Here the application of MATLAB's Simulink was to ease the iteration process of the gear design. The results obtained from both ANSYS and MATLAB's Simulink were close to the results obtained from the AGMA procedure. It also showed that as the face width of the helical gear is increased while keeping other parameters constant, the maximum bending stress at the gear root is decreased. In their study, Karaveer *et al.* [5] used the ANSYS software to conduct contact stress analysis of spur gear and the results of maximum contact stress were found to match the results determined using the theoretical Hertzian formulation. Sanchez *et al.* [6] combined the non-uniform model of load distribution along the lines of contact of spur and helical gears and the equation of linear elasticity to evaluate the bending stress. They proposed their results to be considered for standardization purpose. A study to compare bending stress of helical gears with different materials and modules was conducted by Prabhakaran and Ramachandran [7,8]. By modelling and applying mathematical equations, load distribution at different positions of contact line was obtained and the stress analysis was conducted using the three dimensional FEM. The results showed that the stress values calculated theoretically and determined through the FEM were almost the same. Moreover, Bhosale [9] compared bending stress of a helical gear determined using the modified Lewis formula equation and the ANSYS Workbench software. The results appeared that bending stresses produced at the root of tooth of the helical gear were higher due to the initial point contact at the root of the gear tooth compared to that of the spur gear which had kinematic line contact.

Sarkar *et al.* [10] created 3D models that were differing in helical angle and face width to estimate the bending and contact stresses by using finite element software package. Then, AGMA bending and contact stress equations were used to calculate gear bending stress and contact stress respectively. As a result, this study showed that when face width was increased, the maximum bending stress will decrease. While for gear with lower face width with higher helical angle, it resulted in the increase in the maximum bending stress. Recently, Varatharajulu *et al.* [11] developed software of gear design using Visual Basic but the good work was not integrated with modelling software that allowed for graphic results. In their paper, Padnabadhan *et al.* [12] optimized a gear drive system using the new

Evolutionary Algorithm based Modified Artificial Immune System (MAIS) algorithm. As the results were compared to those of an existing design, the algorithm proves to be accurate.

In this study, bending and contact stress analyses have been conducted on a helical gear of an automotive transmission system using FEM. The aim is to enrich the data on the stress analysis of helical gear applied in car transmission system. A 3D geometric modelling of an involute type helical gear is constructed using a CAD software and stress analyses of the model are conducted using the FEM software of ANSYS. The bending and contact stresses of the gear are validated based on the results determined using the AGMA formulations. Parametric studies are then conducted to study the effect of helical angle and face width on the bending and contact stresses of the helical gear.

2. Material and Methods

This section gives the material properties and geometric specifications of the helical gear under consideration and explains the development of the FEM modelling and analysis conducted on the helical gear.

2.1 Geometric Modelling

This study applies automotive helical gears that are used in a manual car transmission system. Specifically, the 5th gear of the transmission system such as shown in Figure 1 has been analysed. The specification of this gear is as shown in Table 1. The torque and velocity are determined based on the input speed of 4400 RPM. The values for face width and helix angle vary as they act as parameters in the parametric studies to be conducted. The geometric modelling starts by constructing the involute profile of a single gear tooth such as shown in Figure 2. The involute equations are given in Table 1. The single tooth is patterned along the axis of the gear bank to obtain a 2D face of a spur gear. This 2D face of the spur gear is extruded to get the face width of the gear while the face is twisted at a specified angle to give the form of the helical gear. The 3D gear model is then imported to ANSYS environment in order to be applied in the stress analyses that are to be conducted.

Table 1
Geometric and material specifications of the helical gear

No	Parameters	Pinion	Gear
1	Number of teeth, N	29	41
2	Transverse pressure angle, ϕ (°)		21.88°
3	Module, m (mm)		2
4	Dia. of pitch circle, d_p (mm)	58	82
5	Radius of base circle, r_b (mm)	26.91	38.05
6	Addendum, a (mm)		2
7	Dedendum, b (mm)		2.5
8	Face width, F (mm)		Varies
9	Helix angle, ψ (°)		Varies
10	Material		Steel alloy
11	Poisson Ratio, ν		0.28
12	Input speed, n (RPM)	4400	-
13	Torque, T (Nm)		117
14	Velocity, v (m/s)	13.36	
15	Tensile strength, S_{ut} (MPa)		723.83
16	Yield strength, S_y (MPa)		620.42
17	Involute equation	$x(t)=R(\cos(t)+t*\sin(t));$ $y(t)=R(\sin(t)+t*\cos(t));$	



Fig. 1. (a) Gear and (b) pinion of a car transmission system used in this study

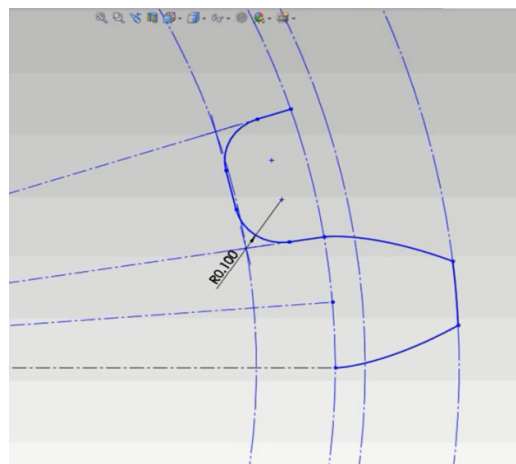

Fig. 2. The involute profile of the gear

2.2 The AGMA Formulation

The AGMA is the responsible authority for developing formulations for the analysis and design of a gear system. The AGMA bending stress equation is [1].

$$\sigma_b = W^t K_o K_v K_s \frac{1}{F m_t} \frac{K_H K_B}{Y_J} \quad (1)$$

where W^t is the tangential transmitted load. K_o , K_v and K_s are the overload, dynamic and the size factors respectively. F and m_t are the face width of the narrower member and the transverse metric module respectively. K_H , K_B and Y_J are the load-distributor factor, the rim thickness factor and the geometry factor for bending strength respectively. In addition, the fundamental AGMA contact stress equation (pitting resistance) is [1]:

$$\sigma_c = Z_E \sqrt{W^t K_o K_v K_s \frac{K_H Z_R}{d_{w1} F Z_I}} \quad (2)$$

where Z_E and W^t are the elastic coefficient and the tangential transmitted load respectively. Z_R and Z_I are the surface condition factor and the geometry factor for pitting resistance, respectively while d_{w1} is the pitch diameter of the pinion and F is the face width of the narrower member of the gear.

2.3 The FEM Modelling

The gears are meshed through automatic meshing procedure in the ANSYS environment. Such meshed gears are shown in Figure 3. In the application of the boundary condition of the model for contact stress analysis, frictionless support which is colored in blue has been applied on the inner rim of both pinion and gear such as shown in Figure 4 (a) and a moment of 117 Nm, colored in red has been applied on the inner rim of the pinion in anti-clockwise direction. For bending stress, the boundary condition is such that fixed support which is colored in blue has been applied on the inner rim of the pinion gear as shown in Figure 4 (b) and force, also known as the face width load of 4034.48 N has been applied on the face of the gear teeth.

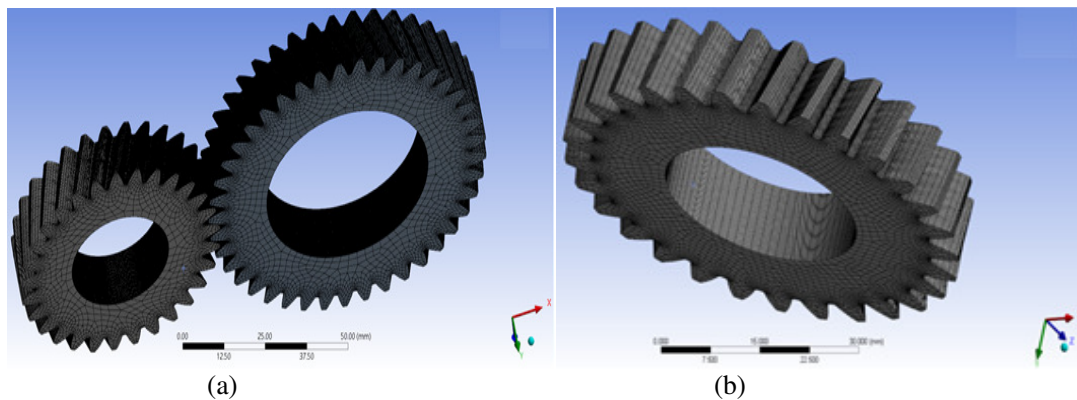

Fig. 3. The meshed helical gear (a) in pairs and (b) alone

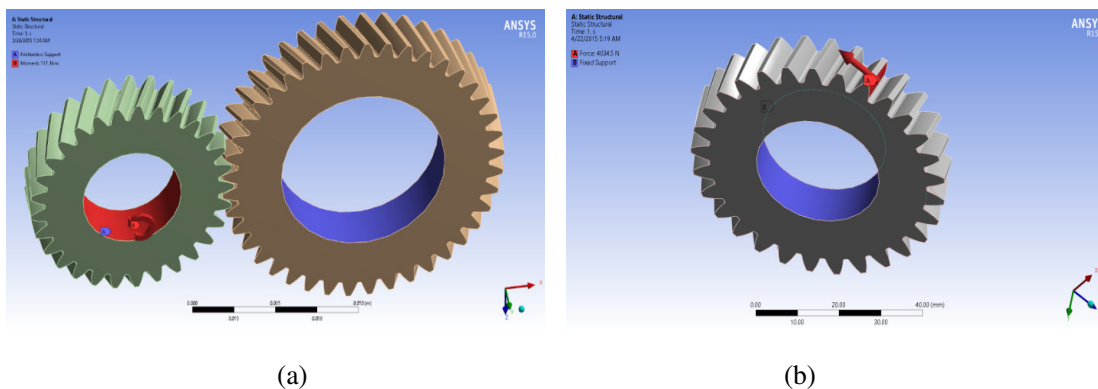

Fig. 4. The loading on the helical gear for (a) contact stress and (b) bending stress

3. Results and Discussion

In this section, sample calculations on both bending and contact stresses using the AGMA formulations are conducted. A comparison of these results with the results of the FEM analysis is

then given. Parametric studies are then reported to show the effect of the face width and helical angle on the bending and surface stresses.

3.1 Stress Analysis of Gear Based on the AGMA Formulation

For the bending stress, face width is taken as $F = 10$ mm and all other factors are as given in Table 1. The tangential load is

$$W_t = \frac{\text{Torque}}{\text{Pitch Radius}} = \frac{117}{0.029} = 4034.48 \text{ N} \quad (3)$$

The dynamic factor is

$$K_v = \sqrt{\frac{78 + \sqrt{200v}}{78}} = \frac{78 + \sqrt{200(13.3623)}}{78} = 1.2895 \quad (4)$$

$$m_t = \frac{m_n}{\cos \beta} = \frac{2}{\cos 20} = 2.1284 \quad (5)$$

To determine the rim-thickness factor,

$$m_B = \frac{t_R}{h_t} = \frac{11.5}{4.5} = 2.56 \quad (6)$$

As $m_B > 1.2$, $K_B = 1$.

$$Y_J = J'_p \times J_{factor} = 0.54(0.958) = 0.51732 \quad (7)$$

So, referring to equation (1), the bending stress is

$$\sigma_b = (4034.48)(1.5)(1.2895)(1) \frac{1}{(10)(2.1284)} \frac{(1.5)(1)}{(0.51732)} = 1063.11 \text{ Mpa} \quad (8)$$

For the surface stress at the helical angle of 25° , the tangential load is

$$W_t = \frac{\text{Torque}}{\text{Pitch Radius}} = \frac{117\text{Nm}}{0.029\text{m}} = 4034.48 \text{ N} \quad (9)$$

$$K_v = \sqrt{\frac{78 + \sqrt{200v}}{78}} = \frac{78 + \sqrt{200(13.3623)}}{78} = 1.2895 \quad (10)$$

$$Z_I = \frac{\cos \phi_t \sin \phi_t}{2m_N} \frac{m_G}{m_G + 1} = \frac{\cos(21.8802^\circ) \sin(21.8802^\circ)}{2(0.06354)} \frac{1.4138}{1.4138 + 1} = 1.5940 \quad (11)$$

So, the pitting stress

$$\sigma_c = 190.3 \sqrt{4034.48 (1.5)(1.2895)(1) \frac{1.5}{58(13)} \frac{(1)}{(1.5940)}} = 593.89 \text{ Mpa} \quad (12)$$

3.2 Stress Analysis based on the FEM

For bending stress, in the case of the face width, $F = 10$ mm, the von Mises's stress contour is shown in Figure 5. The contour shows the maximum stress occurs at the root of the gear as expected where the maximum value of the von Mises stress is 1064 MPa.

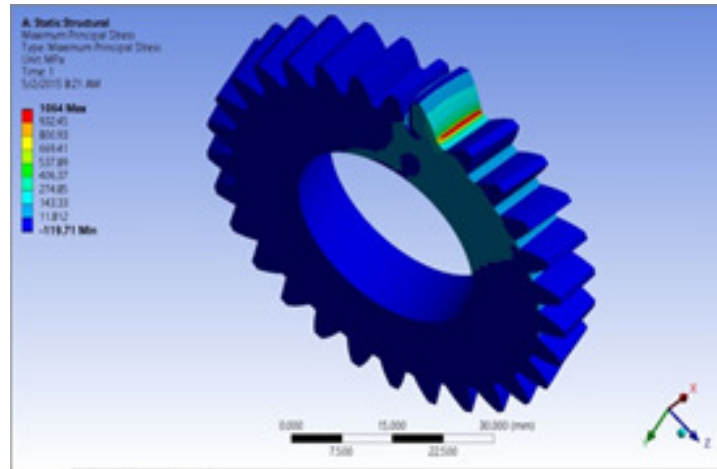

Fig. 5. The von Mises stress of the helical gear

Table 2 shows the values of the maximum von Mises stress as the mesh is refined. As such the maximum stress value of 1064 MPa is taken as the converged value. In the contact stress analysis of the gear, for helical angle of 25° , the maximum von Mises stress is 598.4 MPa such as shown in the stress contour plot in Figure 6.

Table 2
The convergence test

No of elements	Maximum Stress (MPa)	% difference
57940	978.92	-
85453	1054.7	7.45
185703	1064	0.88

3.3 Comparison of the AGMA and the FEM results

Parametric studies have been conducted to investigate the effect of the face width of the gear on the bending stress and the effect of the helical angle on the contact stress of the helical gear. Five values of face width applied here are 10 mm, 14 mm, 18 mm, 22 mm and 26 mm while five different helical angles applied are 25° , 30° , 35° , 40° and 45° . All other parameters and the applied load are kept constant during the simulation involving each case of the face width and the helical angle. Figure 7 shows a plot that compares the values of bending stress correspond to the AGMA and the FEM. It can be seen that the corresponding AGMA and FEM values agree each other excellently.

By referring to Figure 8, there is a variation in the maximum contact stresses with the change of the helical angle, as expected. The maximum contact stress increases non-linearly with the increase of helical angle. This increase is due to the increase length of the contact line area as the helical angle is increased. Furthermore, from the graph the smallest percentage difference occurred at the helical

angle of 45° with the percentage difference between the FEM result and the AGMA result is approximately about 0.23%.

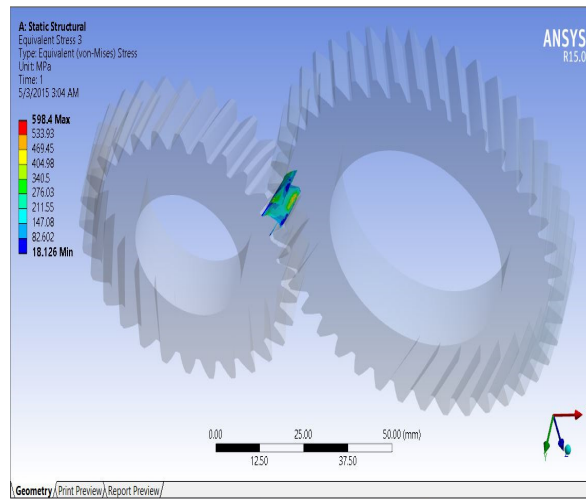

Fig. 6. The contour plot for pitting stress

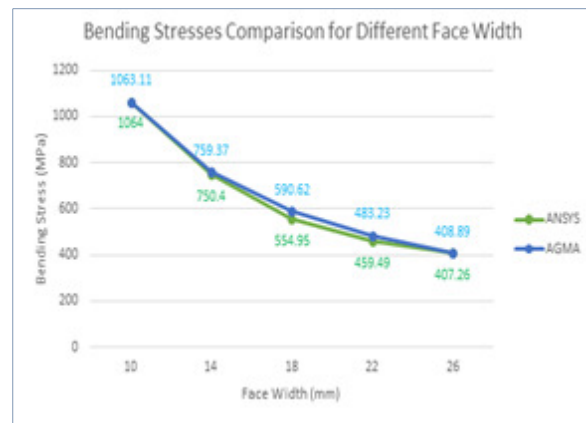

Fig. 7. The comparison of bending stress

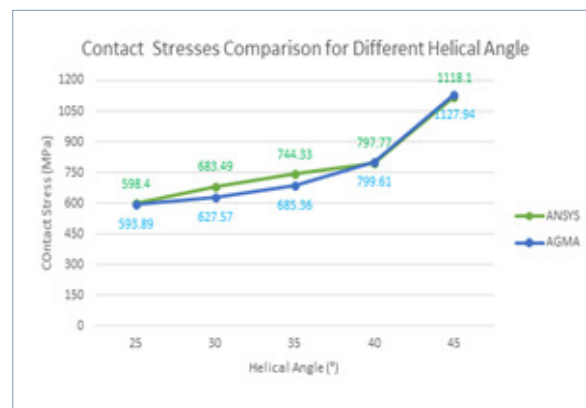

Fig. 8. The comparison of contact stress

4. Conclusion

The bending and contact stress analyses have been conducted on a helical gear that is used in a car transmission system, applying the FEM software of ANSYS. The converged results of the FEM analyses are compared to the results obtained using the AGMA formulation. It has been found that the two results are in good agreement. Furthermore the results of the stress analyses show the right contour of stress and location of maximum stress. From the parametric studies, it can be said that bending stress decreases non-linearly with the increase of the face width of the helical gear while in opposite, the contact stress increases as the helical angle of the gear increases. These findings show that the FEM simulation can provide fast and cheaper results on the stress analysis of helical gears. It is recommended that further stress analyses studies should be conducted on composite helical gears that implement new material such as carbon nanotube in order to improve the stress behavior of the helical gear.

Acknowledgements

This work is supported by the Malaysia's Ministry of Education and the authors would like to express their appreciation to the IDS i-Kohza, Faculty of MJIT, Universiti Teknologi Malaysia and the Ministry for their supports.

References

- [1] Brancati, R., U. Montanaro, E. Rocca, S. Santini, and F. Timpone. "Analysis of bifurcations, rattle and chaos in a gear transmission system." *International Review of Mechanical Engineering (IREME)* 7, no. 4 (2013): 583-591.
- [2] Shigley, Joseph Edward. *Shigley's mechanical engineering design*. Tata McGraw-Hill Education, 2011.
- [3] Ramamurti, V., Nayak H. Vijayendra, and C. Sujatha. "Static and dynamic analysis of spur and bevel gears using FEM." *Mechanism and machine theory* 33, no. 8 (1998): 1177-1193.
- [4] Sairam, N. Venkata, and A. Chandramouli. "Effect of thickness on Interlaminar stresses in clamped FRP angle-ply laminate with a circular cut out." *International Journal of Engineering Trends and Technology* 4 (1994): 3132-3135.
- [5] Karaveer, Vivek, Ashish Mogrekar, and T. Preman Reynold Joseph. "Modeling and finite element analysis of spur gear." *International Journal of Current Engineering and Technology* 3, no. 5 (2013): 2104-2107.
- [6] Sánchez, Miryam B., José I. Pedrero, and Miguel Pleguezuelos. "Critical stress and load conditions for bending calculations of involute spur and helical gears." *International Journal of Fatigue* 48 (2013): 28-38.
- [7] Prabhakaran, S., and S. Ramachandran. "Comparison of bending Stress of a Helical Gear for Different Materials and Modules using AGMA Standards in FEA." In *Applied Mechanics and Materials*, vol. 376, pp. 423-427. Trans Tech Publications, 2013.
- [8] Prabhakaran, S., and S. Ramachandran. "Comparison of Contact Stress of Helical Gear for Steel C45 with AGMA Standard and FEA Model." *International Review of Mechanical Engineering (IREME)* 7, no. 5 (2013): 828-831.
- [9] Bhosale, Kailash C. "Analysis of Bending Strength of helical Gear by FEM." *Innovative Systems Design and Engineering* 2 (2011): 125-128.
- [10] Maske, Narayan A., and J. K. Sawale. "Taguchi Approach For Investigation Of Springback Effect In Aluminum Sheet." *Int. J. Mech. Eng. & Rob. Research* 2 (2013).
- [11] Varatharajulu, M., C. Loganathan, K. Sivaramakrishnan, and R. Ayyappan. "A SOFTWARE DEVELOPMENT IN GEAR DESIGN." *R. J. of Mech. and Civil Eng.* 1 (2014): 11-24.
- [12] Padmanabhan, S., M. Chandrasekaran, P. Asokan, and Raman V. Srinivasa. "Optimal Solution for Gear Drive Design Using Population Based Algorithm." *International Review of Mechanical Engineering (IREME)* 7, no. 5 (2013): 802-806.