

## Potential of Photobioreactors (PBRs) in Cultivation of Microalgae

Anas Al-Dailami<sup>1</sup>, Iwamoto Koji<sup>1,\*</sup>, Imran Ahmad<sup>1</sup>, Masafumi Goto<sup>1</sup>

<sup>1</sup> Malaysia Japan international Institute of Technology, Universiti Teknologi Malaysia, Jalan Sultan Yahya Petra, 54100, Malaysia

### ABSTRACT

The reduction of carbon dioxide concentration in the air (CO<sub>2</sub>) is one of the most important areas for the mitigation of climate change that is being focused on by various studies. The cultivation of microalgae is a tool that can be applied to remove CO<sub>2</sub> from atmosphere as they absorb light and CO<sub>2</sub> and produce molecular oxygen during their cultivation. Wastewater treatment, production of biofuels, biofertilizers, and biomaterials are considered some of the applications of microalgal cultivation. Microalgae can be cultivated in open systems such as simple ponds, circular ponds, and raceway ponds, or in closed systems that are called photobioreactors (PBRs), such as flat panels, vertical tubes, horizontal tubes, and stirred tanks. PBRs have a higher potential as compared to open systems in terms of growth rate, productivity, protection against contamination and the high quality of microalgal biomass. However, the capital and operational cost are still posing an obstruction to installing PBRs for large scale industrial usage. Different types of PBRs with their features are reviewed in this paper, and the potential of PBRs in cultivation of microalgae will be elaborated. This brief review also provides insight to the geometric configurations and mechanisms of PBRs.

### Keywords:

Cultivation, photobioreactors, light intensity, mixing, microalgal biomass

Received: 3 March 2022

Revised: 14 April 2022

Accepted: 25 May 2022

Published: 14 July 2022

## 1. Introduction

Recently, microalgae and its cultivation have been used enormously for various applications such as biofuel, wastewater treatment, pharmaceuticals, and cosmetic products [1-3]. The demand of non-renewable resources of energy has been increased because of the increase in population and urbanization. Hence, microalgae are found as sustainable and renewable resources termed as tiny biorefineries [4]. Microalgae has features that makes it an appropriate alternative as sustainable and renewable resources of energy rather than other resources; can be cultivated in wastewater that reduce the carbon footprint, has a high growth rate, independence of agricultural land, a potential storage of carbon in the carbohydrates and lipids to produce biofuel such as (bioethanol, biomethane, biodiesel and biohydrogen) and other numerous products such as antioxidants, biopeptides, pigments, biopolymers and polysaccharides [5]. Microalgae can be used as food and supplements as the protein could be obtained from algal biomass [6]. The demerits of obtaining

\* Corresponding author.

E-mail address: [k.iwamoto@utm.my](mailto:k.iwamoto@utm.my)

<https://doi.org/10.37934/araset.27.1.3244>

biofuel from microalgae are the high demand of energy and production cost. The stages of processing of microalgae cultivation, harvesting, and drying are costly and not energy efficient. Advanced PBRs technologies and economic downstream processing are critical requisites to achieve the environmentally sustainable metabolites from microalgal biomass and economically viable. Biogenic microalgae can replace the petroleum biorefinery as an alternative solution. Providing the production of biofuel, resource recovery and minimizing the overall cost of upstream (strain selection, nutrients, light, and aeration) and downstream processes are underlying the concept of the algal biorefinery.

CO<sub>2</sub> is absorbed by microalgae during exposure to the light and it leads to produce the energy. The role of photosynthetic process is to produce the glucose by fixing CO<sub>2</sub>, so the CO<sub>2</sub> amount in the atmosphere can be reduced by enhancing the photosynthetic efficiency of microalgae. Carbohydrates, proteins, lipids, and CO<sub>2</sub> are required to produce glucose [7]. Microalgal photosynthesis includes light and dark reactions (Calvin cycle). Light reaction cycles occur in the thylakoids converting light energy to chemical energy, while in the dark cycle the active chemical energy is transformed to stable chemical energy. The process is depicted in Figure 1.

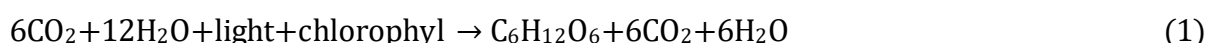

Microalgae can be cultivated in open or closed PBRs [8]. The open systems have several advantages such as easier to construct and operate compared to closed systems, while closed systems also possess some merits such as better control of temperature and pH concentrations, efficient light distribution, and minimization of contamination from outside and the productivity of microalgal biomass is higher as compared to open ponds systems [9]. Nevertheless, the limitations of closed PBRs systems are the capital cost of PBRs, high shear stress that damage the cells and the difficulties in scaling up [10, 11].

The current research gains interest in improving the producing of biomass from microalgae cultivation through the advancement of PBRs' parameters [12]. Light, nutrient, CO<sub>2</sub>, and mixing are required factors to cultivate microalga [2, 7]. So far, the productivity of microalgae is still facing hurdles in terms of large amount [13]. Efficient and developed closed PBRs systems can overcome the hurdles that affect microalgae growth, such as high cost and limiting their commercial applications to high-valued compounds [14]. PBRs design parameters are also dependent on penetration and distribution of light, as well as supply of CO<sub>2</sub>.

PBRs are sophisticated systems that provide the appropriate environment and conditions of cultivation for microalgae. The conditions of operating that including temperature, light, nutrients, and mixing are regulated, monitored, and controlled to maximize the yield of algal biomass [15]. The installation of PBRs can be indoor to exposure the artificial light or outdoor to exposure the sunlight and that cultivation called photoautotrophic microalgae cultivation as the sunlight or artificial light supply the energy [16]. Recently, dozens of novel PBRs were being designed and manufactured, but the most common PBRs that used are flat panel, stirred tank and tubular. Regarding their merits and demerits are depended on biomass yield, operation mode and upscaling level [17]. Day by day, the research is being gained enormous interest continuously and the PBRs have been improved and modified to adopt algal species under varying cultivation conditions in the environment, optimize algal biomass yield, and commercialize the applications [18]. The potential of different PBRs such as flat panel, stirred tank and tubular that including vertical, horizontal, and U-shaped PBR will be discussed, and their configurations and processing of microalgae cultivation will be detailed in this review.

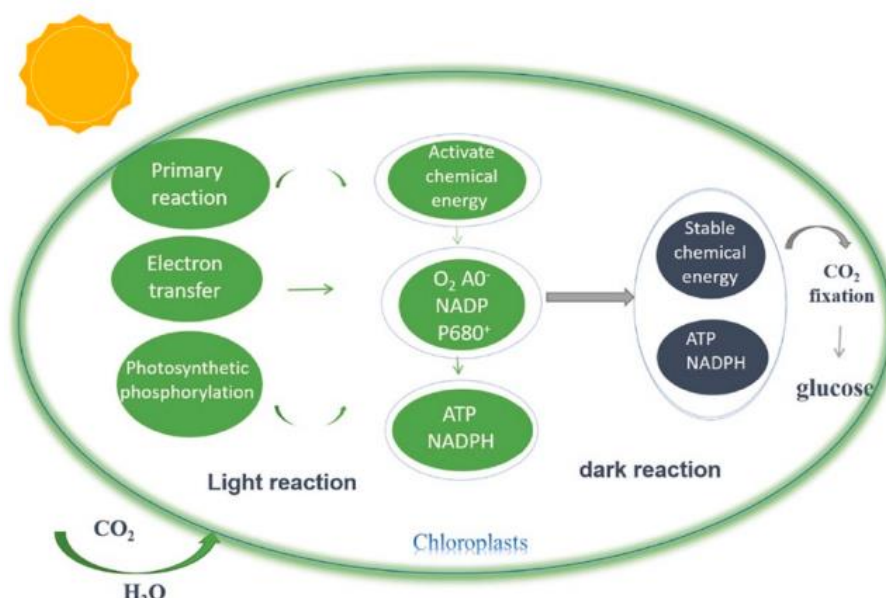

**Fig. 1.** Microalgae photosynthesis reaction [19]

## 2. Comparing open ponds and photobioreactors

The life cycle impact of energy consumption for microalgae cultivation should be taken into consideration, especially the processing of biomass and lipid extraction, as they are the most energy-intensive [20]. New advanced technologies are required to reduce energy consumption and CO<sub>2</sub> emissions while also increasing the biomass productivity of microalgae. Minimization of maintenance costs and maximisation of production of microalgae are crucial factors that should be achieved in the long term [21]. Table 1 illustrates the cost structure for algae cultivation in open ponds compared to PBRs. As shown, the capital cost of PBRs is 82.7% as the cost of construction, while 15.4% is the cost of ponds exclusive of other structures of the systems. Products, nutrients, harvest technologies, and biomass drying are factors that affect the cost-effectiveness of algae production.

**Table 1**

comparing the capital cost structure of systems in open pond system and PBRs adopted from [20, 22, 23]

Capital cost structure of systems	Open pond system	PBR
Harvesting	21.0%	6.5%
Ponds	15.4%	-
PBR	-	82.7%
Inoculum system	12.3%	3.8%
Land costs	11.3%	3.5%
Extraction	8.2%	2.5%
Digestion	11.8%	3.6%
OSBL Equipment	10.8%	3.3%
CO <sub>2</sub> delivery	6.2%	1.9%
Hydrotreating	12.3%	1.4%

The cost of 1 kg of algae production from raceways ponds is estimated to be around \$16.4, while the cost of PBR production is estimated to be around \$33 [20]. Furthermore, it is estimated that production of 1 kg of algae needs about 1 acre and that might cost about \$11. However, increasing the acres to 100 using high advanced technologies is required to minimise the cost of production to about \$4.4 [22]. The cost of cultivating microalgae in an open pond is cheaper than using a PBR, even though the biomass productivity is higher and more controllable in the PBR.

### 3. Photobioreactors

Numerous studies have recently focused on closed PBR systems. Closed systems have no direct gas exchange with the outside environment and that critically leads to minimising the contamination from the outside environment [9], as the microalgae are entirely cultured and enclosed in the PBR [24]. The purpose of the design of a closed system is to overcome the hurdles of open systems [25]. The efficiency of receiving sunlight in closed systems is higher than in open pond systems as it has two stages of receiving sunlight: (1) directly receiving light from the first area and (2) collecting distributed light from the second area [26]. In closed systems, the conditions of microalgae cultivation are controllable within high-value productivity [9]. They have various merits, such as controlling temperature, intensive sunlight and PH concentrations, minimization of CO<sub>2</sub> and contamination from outside, and the quality of microalgae production is high compared with open pond systems [27]. However, the building and operating systems of closed PBR systems are still facing obstructions relevant to economic aspects compared to open systems [25]. Hence, it is worth developing to substitute OPS because its products have high quality and a massive growth rate of productivity [28]. Many versions of PBR closed systems have been created by researchers, such as flat panel PBRs, tubular PBRs, and stirred tank PBRs [29]. According to the classification of photobioreactors based on geometry and cultivation processing, Figure 2 shows that PBRs are categorised mainly into flat panel, tubular, pyramid, fermenter, and hybrid. Among those PBRs, the tubular reactor is known as the most common use [14].

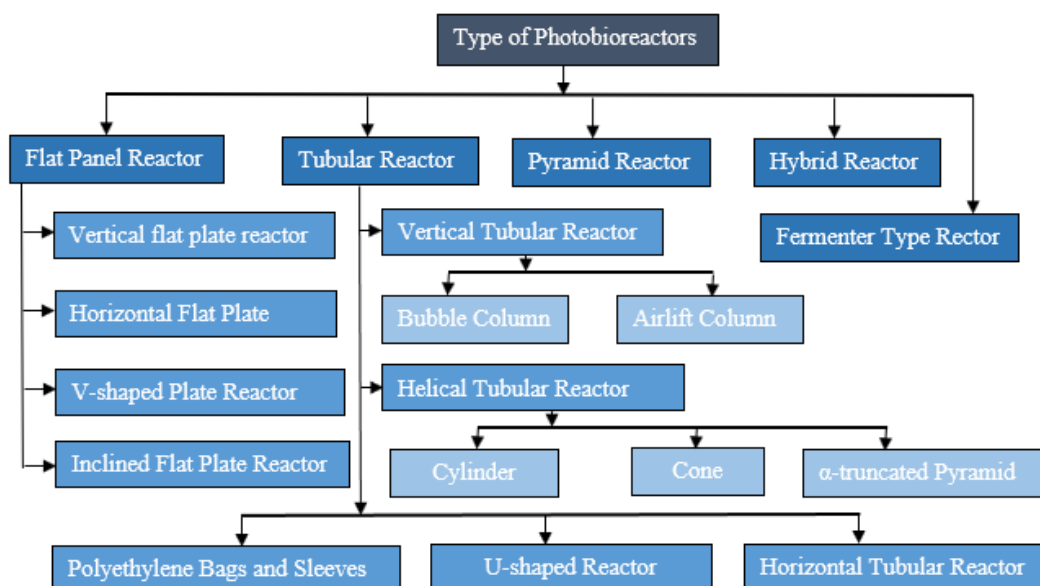

Fig. 2. The main classification of PBRs based on the shape modified and adopted from [14]

PBRs have some advantages and disadvantages depending upon the biotic and abiotic conditions employed in the cultivation of different microalgal species. The pros and cons of the PBRs explained in the paper are summarized in Table 2

**Table 2**

Comparing the advantages and limitations of different PBRs used for microalgae cultivation [14, 30-33]

Type of Photobioreactor	Advantages	Limitations
Vertical photobioreactors (Airlift and bubble column)	<ul style="list-style-type: none"> <li>• Excellent biomass productivity</li> <li>• High efficiency of photosynthesis</li> <li>• Limitation of photo-inhibition and photooxidation</li> <li>• Small land required for construction</li> <li>• Appropriate for outdoor cultivation</li> <li>• Low contamination risk</li> <li>• Low energy required</li> <li>• Low cost, relatively small size and easily maintain</li> </ul>	<ul style="list-style-type: none"> <li>• possibility of cell shear stress</li> <li>• low light exposure and low illumination area</li> <li>• susceptibility of biofouling on walls of reactor</li> </ul>
Horizontal	<ul style="list-style-type: none"> <li>• High surface to volume ratio</li> <li>• High exposure with optimum use of light</li> <li>• Appropriate for outdoor cultures</li> <li>• Relatively excellent biomass output</li> <li>• Suitable position towards sunlight</li> <li>• Maximum use of received light</li> <li>• Reasonable cost</li> <li>• Relatively easy scalability</li> </ul>	<ul style="list-style-type: none"> <li>• Accumulation of dissolved oxygen risky</li> <li>• Possibility of biofouling</li> <li>• Required large land</li> <li>• Photo-inhibition</li> <li>• possibility of cells shear stress</li> <li>• Separate gas exchange unit demanded</li> </ul>
Flat plate	<ul style="list-style-type: none"> <li>• Maximum exposure to sunlight</li> <li>• High ratio of surface to volume</li> <li>• Well-appropriate for outdoor farming</li> <li>• High productivity of biomass</li> <li>• Well-distributed of total light for cultivation</li> <li>• Relatively cheap cost</li> <li>• Easy to construct, clean and handle</li> <li>• High photosynthesis efficacy</li> <li>• Low concentration of dissolved oxygen</li> </ul>	<ul style="list-style-type: none"> <li>• Difficulty of Scalability</li> <li>• Difficulty of cultivation temperature regulating</li> <li>• Possibility biofouling</li> <li>• Possibility of hydrodynamic stress in algae cells</li> </ul>
Stirred tank	<ul style="list-style-type: none"> <li>• Running axenic cultivation possible</li> <li>• possibility of open gas exchange</li> <li>• purposing use for optimization analysis</li> <li>• Controllable of all parameters of process</li> </ul>	<ul style="list-style-type: none"> <li>• Low ratio of surface to volume</li> <li>• Low accessibility of light exposure</li> <li>• Low biomass output</li> <li>• Expensive of operation cost</li> </ul>

### 3.1 Flat panel Photobioreactor

The materials that are used to construct the flat panel reactor are transparent materials like glass, plexiglass, polycarbonate, and other similar materials [34]. The flat panel reactor is appropriate for both indoor and outdoor cultivation as its light path is short, and it eases the penetration of light. The panels of the reactor can be placed vertical or inclined based on  $\alpha$  angle that is shown in figure 3 to maximize the exposure of light from light sources [3]. Bubbled air or air rotated mechanically are the

two methods that increase the mixing rate, which increases biomass productivity. Besides that, the reactors have a high ratio of surface area to volume, and its construction is simple [31]. Furthermore, scaling up in a flat panel is easier than in a horizontal photobioreactor tubular because the flat panel has a larger illumination surface area. Flat plate bioreactor has some limitations such as aeration rates, temperature control during cultivation, and biofouling [32]. In terms of processing, as such, the optimization of cultivation is required to maximise the biomass production, the decline of the energy consumption during the processing of cultivation should also be considered.

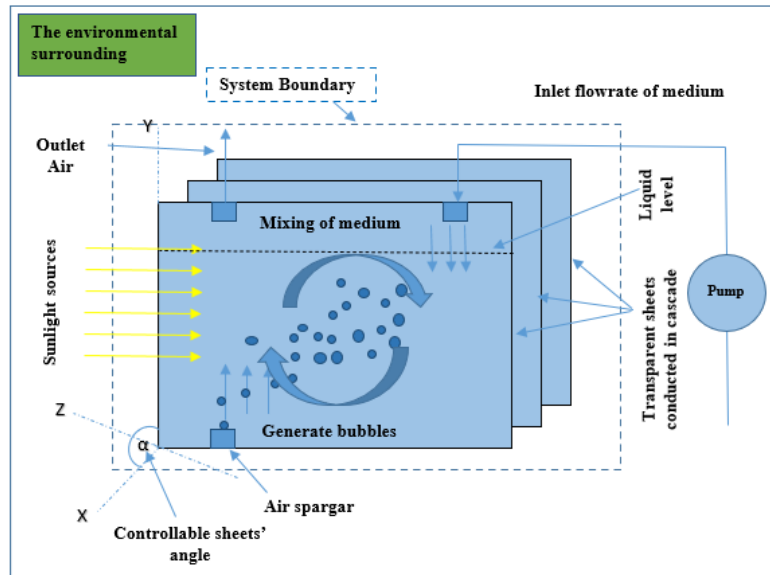

Fig. 3. Flat panel PBR modified and adopted from [35]

### 3.2 Stirred tank Photobioreactors

The basic design of the stirred tank reactor that is used in microalgae cultivation was taken from the fermenter tank design [35]. The concept of the processing is almost similar, but external light resources are required for microalgae cultivation [35, 36]. The mechanical movement from the agitator aids in maximising the optimal heat and mass transfer, and it contributes to the mixing of the culture medium efficiently. Furthermore, providing aeration can help to increase gas solubility [3]. However, the ratio of surface to volume is low, and that leads to a decrease in the efficiency of microalgal photosynthesis [1, 30]. Regarding medium utilization, it is crucial to use the appropriate medium that is driven from the medium tank to the reactor. Different medium utilisation affects the productivity of oil, as the high concentration of salt medium is likely to decrease the growth of biomass. However, the amount of extracted lipid will be high depending on the type of medium as it is needed to optimise the production of lipid [37]. Currently, the purpose of stirred tanks is only for laboratory scale utilisation because the adequate exposure of light for microalgae cultivation might be affected in the larger vessel. The stirred tank needs to be more developed to increase the concentration of biomass productivity continuously and accordingly on a large-scale design. Figure 4 shows the basic principles of stirred tank design.

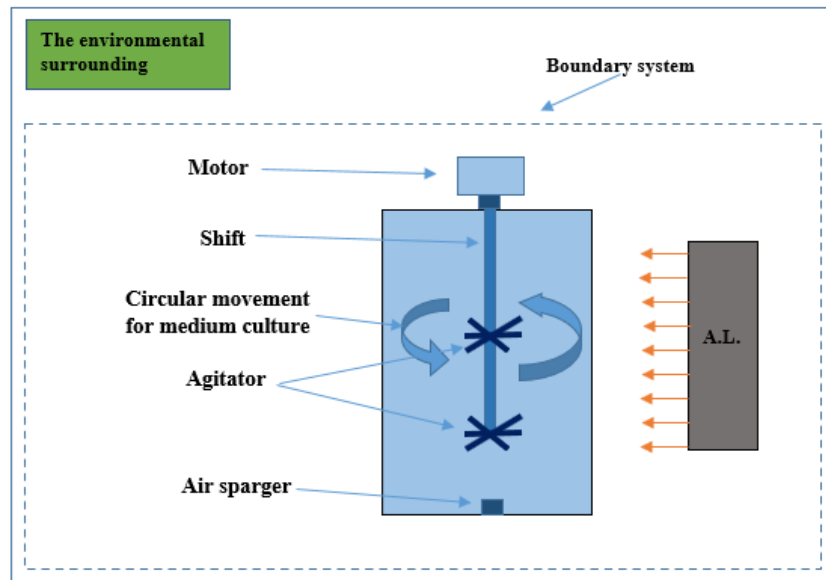

Fig. 4. stirred tank PBR modified and adopted from [35]

### 3.3 Tubular Photobioreactors

The tubular PBRs are considered the most used among other types of PBRs due to the high amount of biomass it produces during a short time of cultivation and harvesting [33]. To increase the efficiency of receiving sunlight, the materials of tubes are transparent, such as plastic or glass, and constructed parallelly. The diameter of the tubes is equal or less than 0.2m. They provide a pump or airlift technology that circulates microalgae through the tubes [38, 39]. Tubular PBRs have various configurations, such as vertical tube photobioreactors, including bubble column and airlift reactors, horizontal tube reactors, helical tubes, and most recently, U-shaped reactors. The shape of the reactor plays a crucial role in converting the light energy according to its positioning towards the sun during outdoor culture [33]. A CO<sub>2</sub> gas mixture is introduced into the tube connection by using a dedicated gas exchange system. However, providing deoxygenation mechanisms effectively is essential to enhance dissolved oxygen as a photobleaching phenomenon happens during the accumulation of oxygen through low efficiency photosynthesis [30].

#### 3.3.1 Vertical tube Photobioreactors

The design of the vertical tube PBR can be categorised into two types: bubble column and airlift column. There are common merits to vertical photobioreactor designs. For example, the air sparger is installed at the bottom, which boosts mass transfer and increases the mixing rate for algae with culture medium [40]. The bubble column design is a cylindrical column shape that does not have a structure inside and not having a moving part [41]. The path movement of fluid from the bottom to the top is driven by air bubbles that are generated by an air sparger [42, 43]. The bubble column design has many features; the ratio of surface to volume is high, and mass transfer is satisfied. The resource of light is external, which enhances the efficiency of mixing and photosynthetic. They are then motivated to move from the light-lit zone into a dark, central area [3].

The airlift reactor is defined as the improved design of the bubble column. The airlift reactor is designed with an internal structure with a riser zone and a downcomer zone. The role of air bubbles is to drive the liquid from the dark zone (riser zone) to the illuminated zone (outside zone), and this process is called airlift [44]. The liquid is a cycle between the dark zone and the light zone. The merits

of cultivation of microalgae in the airlift are that the mixing is more dynamic with low shear stress, and the mass transfer is efficient [35]. The intrusion of bubbles positively effects the microalgal growth rate by increasing the surface area for the water-gas phase and removing the oxygen produced during microalgal growth. The highest photosynthetic conversion rate and volumetric productivity are possessed by vertical PBRs [35, 45]. Moreover, if the light interception is further increased, it can enhance the photosynthetic conversion rate as well as areal productivity. The advantages of vertical PBRs promise to be an appropriate option on a large scale, but the capital cost is high. The design still needs to be considered to minimise the cost of implementation [46]. Generally, "tubular PBR " is a description of any type of photobioreactor that has a tube in its design. The potential for microalgae cultivation is high compared to that of open pond systems [47].

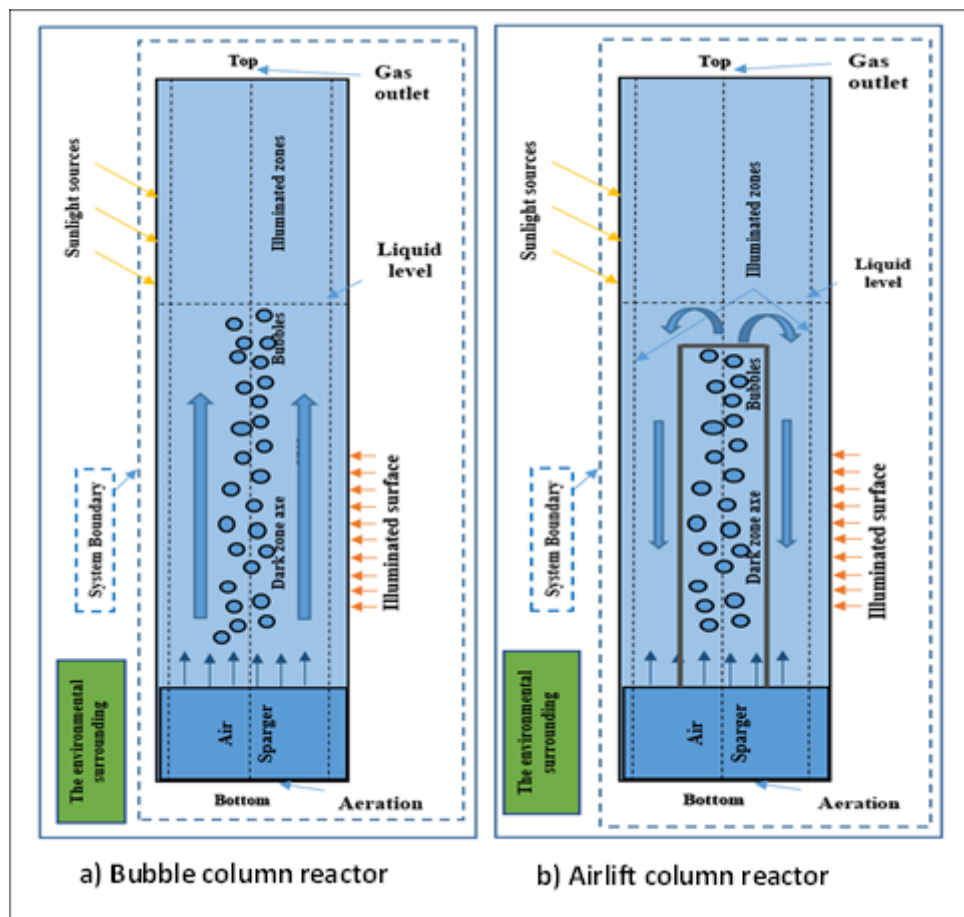

Fig. 5. Types of vertical tube PBR modified and adopted from [35]

### 3.3.2 Horizontal Photobioreactors

The horizontal tube PBR is known as the first constructed type of closed reactor to cultivate microalgae [35]. It has long tubes that can be positioned in various shapes, such as walls, helices, or panels. A large area is required to install the horizontal PBR as it has a high surface. Hence, the surface area is permeable to the light due to the small diameter and the long distance of the tube [45]. The culture medium is circulated during exposure to the light source and back to the reservoir by pump [48]. The flow regime should be continuously high-turbulent. To be sure, periodic maintenance of the reactor is required to avoid the flocculation of microalgae [39]. As a requirement to continue the processing of cultivation in the system, some of the biomass must be harvested. As compared, a study showed that artificial light increases the value of microalgal productivity much better than



sunlight in terms of products. Even though, the positioning of tubes tightly to each other can increase areal production, the exposure of light on the tubes will be decreased. A smaller diameter and a length of tube are required to avoid the accumulation of oxygen and increasing the density of productivity. The dissolved oxygen in the horizontal reactor is lower compared to the vertical type of PBR as the height of tube would increase the tank pressure and that lead to drive more oxygen to the medium [49].

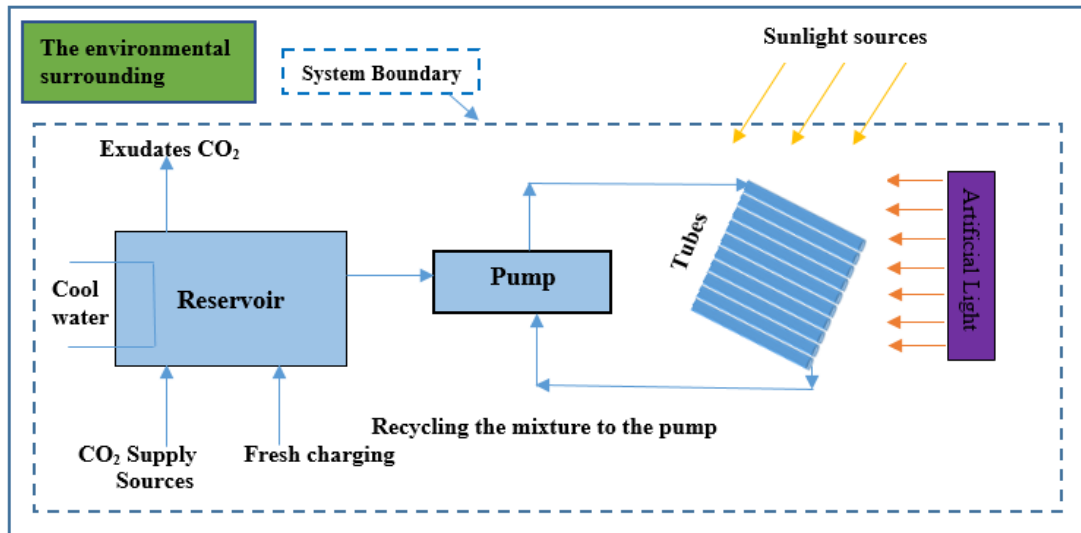
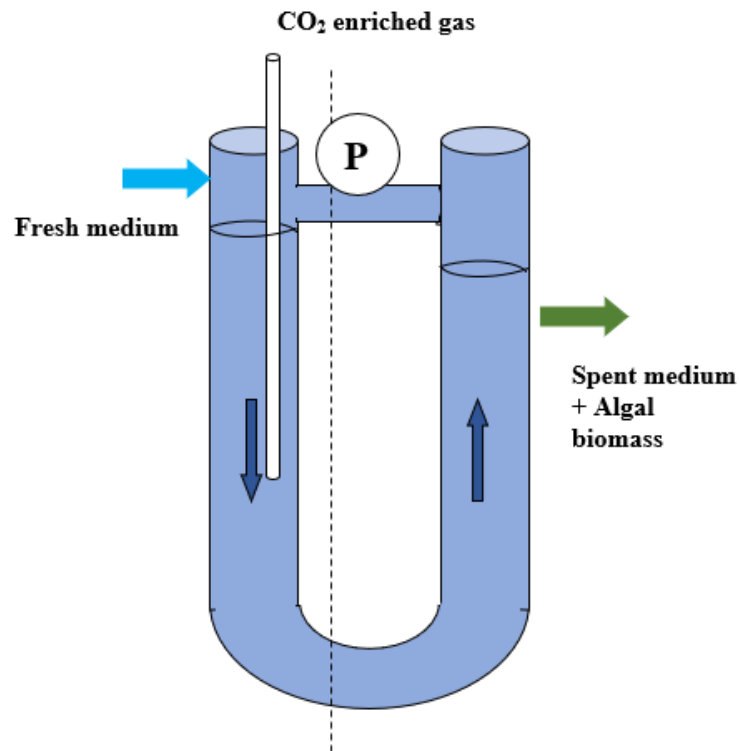

Fig. 6. Horizontal tube PBR modified and adopted from [35]

### 3.3.3 U-shaped Photobioreactors

The U-shaped PBR is a novel tubular photobioreactor that cylindrical tube is designed as U letter shape. No studies have discussed the design, operation, and cultivation of microalgae in the PBR. Figure 7 shows the design of U-shape PBR in terms of geometry. Accordingly on the operating procedure of U-system, one peristaltic pump is used as supply pump for U-system. The peristaltic pump transfers medium from medium preparation tank into U-panels. The same goes for discharge pump. It transfers cultivated algae from U-panel harvesting tank. The peristaltic pump is controlled by dispensing volume and discharge pump is controlled by timer. Each U-panel is equipped with one re-circulation pump, in order to continuously stir the medium. Each U-panel installed with one thermocouple as well. One pH and DO sensor is shared between three U-panels in one U-system. The working volume of 1 tube panel is 35 L. U-tube system contains; 1) RP (re-circulation pump), 2) temperature probe, 3) DO (Dissolved Oxygen) probe, 4) pH measuring probe and 5) light sensor. As U-system is equipped with one DO and pH sensors, that means one pH and DO sensors are shaped between three individual U-shaped panels. The sensors are mount on the stainless-steel probe. The probe needs to be inserted on top on the U-panel. The display for each sensor is mount on the side of U-system frame.



**Fig. 7.** U-shaped PBR

The geometry of the U-shaped PBR resembles a manometric and its flow is recirculatory. Hence, the path of flow may help to minimise energy consumption. In this case, the generation of energy from pumps and aeration might be decreased. For future studies, investigating the optimization of cultivation conditions in a U-shaped PBR is required. To do that, the hydrodynamic characteristics need to be identified, such as velocity, viscosity, and turbulence. In terms of novelty, a U-shaped reactor can be developed by installing a static mixer. A static mixer may increase the productivity of algae as the mixing of nutrition and light will be increased [50].

#### 4. Conclusions

Recently with increasing the global warming, microalgae have gained interested to mitigate the carbon dioxide as it can be used with various applications that sounds environmentally friendly. It is critical that the performance of microalgae cultivation is depended on choosing the PBR under the appropriate conditions of culture. There are thousands algal species and every type of species has own possesses conditions of growth, so the strain of microalgae mainly contributes to identify the suitable conditions of growth. Cultivation of microalgae in PBRs must deal with numerous challenges. Furthermore, the type of PBRs should be chosen accordingly on its design with choosing algal species since every type of photobioreactor has several designs. Although, the open pond systems have many limitations, they are still suggested to use for reducing the carbon dioxide that released from industries and power plant, to treat the wastewater and to produce the biofuel. The large scale of microalgae cultivation is coming with open pond system comparing closed system, so it is suitable to produce biofuel. However, microalgae cultivation in closed system leads to a good quality since it is not contaminated from surrounding, therefore it is defiantly appropriate for cosmetic and pharmaceuticals products. PBRs are worth more efforts to overcome the hurdles and be more

developed. Sometimes, there are suggested hybrid PBR systems that can overcome some limitations and minimize the losses such as water and energy.

## Acknowledgement

The authors are thankful for the Algae and Biomass Research laboratory setup provided by MJIT.

## References

- [1] Gupta, Prabuddha L., Seung-Mok Lee, and Hee-Jeong Choi. "A mini review: photobioreactors for large scale algal cultivation." *World Journal of Microbiology and Biotechnology* 31, no. 9 (2015): 1409-1417. <https://doi.org/10.1007/s11274-015-1892-4>
- [2] Acién, F. G., E. Molina, A. Reis, G. Torzillo, G. Chini Zittelli, C. Sepúlveda, and J. Masojídek. "Photobioreactors for the production of microalgae." In *Microalgae-based biofuels and bioproducts*, pp. 1-44. Woodhead Publishing, 2017. <https://doi.org/10.1016/B978-0-08-101023-5.00001-7>
- [3] Ting, Han, Lu Haifeng, Ma Shanshan, Yuanhui Zhang, Liu Zhidan, and Duan Na. "Progress in microalgae cultivation photobioreactors and applications in wastewater treatment: A review." *International Journal of Agricultural and Biological Engineering* 10, no. 1 (2017): 1-29.
- [4] Ahmad, Imran, Norhayati Abdullah, Koji Iwamoto, and Ali Yuzir. "The Contribution of Microalgae in Bio-refinery and Resource Recovery: A Sustainable Approach leading to Circular Bioeconomy." *Chemical Engineering Transactions* 89 (2021): 391-396.
- [5] Banu, J. Rajesh, S. Kavitha, M. Gunasekaran, and Gopalakrishnan Kumar. "Microalgae based biorefinery promoting circular bioeconomy-techno economic and life-cycle analysis." *Bioresource technology* 302 (2020): 122822. <https://doi.org/10.1016/j.biortech.2020.122822>
- [6] Ahmad, I., A. Yuzir, S. E. Mohamad, K. Iwamoto, and N. Abdullah. "Role of microalgae in sustainable energy and environment." In *IOP Conference Series: Materials Science and Engineering*, vol. 1051, no. 1, p. 012059. IOP Publishing, 2021. <https://doi.org/10.1088/1757-899X/1051/1/012059>
- [7] Okoro, Victor, Ulugbek Azimov, Jose Munoz, Hector H. Hernandez, and Anh N. Phan. "Microalgae cultivation and harvesting: Growth performance and use of flocculants-A review." *Renewable and Sustainable Energy Reviews* 115 (2019): 109364. <https://doi.org/10.1016/j.rser.2019.109364>
- [8] Narala, Rakesh R., Sourabh Garg, Kalpesh K. Sharma, Skye R. Thomas-Hall, Miklos Deme, Yan Li, and Peer M. Schenk. "Comparison of microalgae cultivation in photobioreactor, open raceway pond, and a two-stage hybrid system." *Frontiers in Energy Research* 4 (2016): 29. <https://doi.org/10.3389/fenrg.2016.00029>
- [9] Yen, Hong-Wei, I-Chen Hu, Chun-Yen Chen, Dillirani Nagarajan, and Jo-Shu Chang. "Design of photobioreactors for algal cultivation." In *Biofuels from algae*, pp. 225-256. Elsevier, 2019. <https://doi.org/10.1016/B978-0-444-64192-2.00010-X>
- [10] Brennan, Liam, and Philip Owende. "Biofuels from microalgae—a review of technologies for production, processing, and extractions of biofuels and co-products." *Renewable and sustainable energy reviews* 14, no. 2 (2010): 557-577. <https://doi.org/10.1016/j.rser.2009.10.009>
- [11] Popa, Valentin I., and Irina Volf, eds. *Biomass as renewable raw material to obtain bioproducts of high-tech value*. Elsevier, 2018.
- [12] Hossain, Nazia, and Teuku Meurah Indra Mahlia. "Progress in physicochemical parameters of microalgae cultivation for biofuel production." *Critical reviews in biotechnology* 39, no. 6 (2019): 835-859. <https://doi.org/10.1080/07388551.2019.1624945>
- [13] Sandefur, Heather N., Maryam Asgharpour, Jason Mariott, Emily Gottberg, Jessica Vaden, Marty Matlock, and Jamie Hestekin. "Recovery of nutrients from swine wastewater using ultrafiltration: Applications for microalgae cultivation in photobioreactors." *Ecological Engineering* 94 (2016): 75-81. <https://doi.org/10.1016/j.ecoleng.2016.05.066>
- [14] Płaczek, Małgorzata, Agnieszka Patyna, and Stanisław Witczak. "Technical evaluation of photobioreactors for microalgae cultivation." In *E3S web of conferences*, vol. 19, p. 02032. EDP Sciences, 2017. <https://doi.org/10.1051/e3sconf/20171902032>
- [15] Huang, Qingshan, Fuhua Jiang, Lianzhou Wang, and Chao Yang. "Design of photobioreactors for mass cultivation of photosynthetic organisms." *Engineering* 3, no. 3 (2017): 318-329. <https://doi.org/10.1016/j.ENG.2017.03.020>
- [16] Ahmad, Imran, Norhayati Abdullah, Iwamoto Koji, Ali Yuzir, and Shaza Eva Muhammad. "Evolution of Photobioreactors: A Review based on Microalgal Perspective." In *IOP Conference Series: Materials Science and Engineering*, vol. 1142, no. 1, p. 012004. IOP Publishing, 2021. <https://doi.org/10.1088/1757-899X/1142/1/012004>

- [17] Yadala, Soumya, and Selen Cremaschi. "Design and optimization of artificial cultivation units for algae production." *Energy* 78 (2014): 23-39. <https://doi.org/10.1016/j.energy.2014.06.001>
- [18] Sheng, A. L. K., M. R. Bilad, N. B. Osman, and N. Arahman. "Sequencing batch membrane photobioreactor for real secondary effluent polishing using native microalgae: Process performance and full-scale projection." *Journal of Cleaner Production* 168 (2017): 708-715. <https://doi.org/10.1016/j.jclepro.2017.09.083>
- [19] Yin, Zhihong, Liandong Zhu, Shuangxi Li, Tianyi Hu, Ruoyu Chu, Fan Mo, Dan Hu, Chenchen Liu, and Bin Li. "A comprehensive review on cultivation and harvesting of microalgae for biodiesel production: Environmental pollution control and future directions." *Bioresource Technology* 301 (2020): 122804. <https://doi.org/10.1016/j.biortech.2020.122804>
- [20] Bošnjaković, Mladen, and Nazaruddin Sinaga. "The perspective of large-scale production of algae biodiesel." *Applied Sciences* 10, no. 22 (2020): 8181. <https://doi.org/10.3390/app10228181>
- [21] Gendy, Tahani S., and Seham A. El-Temtamy. "Commercialization potential aspects of microalgae for biofuel production: an overview." *Egyptian Journal of Petroleum* 22, no. 1 (2013): 43-51. <https://doi.org/10.1016/j.ejpe.2012.07.001>
- [22] Davis, Ryan, Andy Aden, and Philip T. Pienkos. "Techno-economic analysis of autotrophic microalgae for fuel production." *Applied Energy* 88, no. 10 (2011): 3524-3531. <https://doi.org/10.1016/j.apenergy.2011.04.018>
- [23] Zhu, Yunhua, Susanne B. Jones, and Daniel B. Anderson. *Algae farm cost model: Considerations for photobioreactors*. No. PNNL-28201. Pacific Northwest National Lab.(PNNL), Richland, WA (United States), 2018.
- [24] Yen, Hong-Wei, I-Chen Hu, Chun-Yen Chen, Dillirani Nagarajan, and Jo-Shu Chang. "Design of photobioreactors for algal cultivation." In *Biofuels from algae*, pp. 225-256. Elsevier, 2019. <https://doi.org/10.1016/B978-0-444-64192-2.00010-X>
- [25] Clippinger, Jennifer N., and Ryan E. Davis. *Techno-economic analysis for the production of algal biomass via closed photobioreactors: future cost potential evaluated across a range of cultivation system designs*. No. NREL/TP-5100-72716. National Renewable Energy Lab.(NREL), Golden, CO (United States), 2019. <https://doi.org/10.2172/1566806>
- [26] Chang, J-S., P-L. Show, T-C. Ling, C-Y. Chen, S-H. Ho, C-H. Tan, D. Nagarajan, and W-N. Phong. "Photobioreactors." In *Current developments in biotechnology and bioengineering*, pp. 313-352. Elsevier, 2017. <https://doi.org/10.1016/B978-0-444-63663-8.00011-2>
- [27] Koller, Martin. "Design of closed photobioreactors for algal cultivation." In *Algal biorefineries*, pp. 133-186. Springer, Cham, 2015. [https://doi.org/10.1007/978-3-319-20200-6\\_4](https://doi.org/10.1007/978-3-319-20200-6_4)
- [28] Cui, Xuyang, Junhong Yang, Yuanzheng Feng, and Wenwen Zhang. "Simulation of a novel tubular microalgae photobioreactor with aerated tangent inner tubes: improvements in mixing performance and flashing-light effects." *Archaea* 2020 (2020). <https://doi.org/10.1155/2020/8815263>
- [29] Egbo, M. K., A. O. Okoani, and I. E. Okoh. "Photobioreactors for microalgae cultivation—An overview." *Int J Sci Eng Res* 9 (2018): 65-74.
- [30] Singh, R. N., and Shaishav Sharma. "Development of suitable photobioreactor for algae production—A review." *Renewable and Sustainable Energy Reviews* 16, no. 4 (2012): 2347-2353. <https://doi.org/10.1016/j.rser.2012.01.026>
- [31] Bahadar, Ali, and M. Bilal Khan. "Progress in energy from microalgae: a review." *Renewable and Sustainable Energy Reviews* 27 (2013): 128-148. <https://doi.org/10.1016/j.rser.2013.06.029>
- [32] Liu, Xiao-ya, and Yu Hong. "Microalgae-based wastewater treatment and recovery with biomass and value-added products: a brief review." *Current Pollution Reports* 7, no. 2 (2021): 227-245. <https://doi.org/10.1007/s40726-021-00184-6>
- [33] Siddiki, Sk Yasir Arafat, M. Mofijur, P. Senthil Kumar, Shams Forruque Ahmed, Abrar Inayat, F. Kusumo, Irfan Anjum Badruddin et al. "Microalgae biomass as a sustainable source for biofuel, biochemical and biobased value-added products: An integrated biorefinery concept." *Fuel* 307 (2022): 121782. <https://doi.org/10.1016/j.fuel.2021.121782>
- [34] Madhubalaji, C. K., Ajam Shekh, P. V. Sijil, Sandeep Mudliar, Vikas Singh Chauhan, Ravi Sarada, Ambati Ranga Rao, and Gokare A. Ravishankar. "Open cultivation systems and closed photobioreactors for microalgal cultivation and biomass production." *Handbook of algal technologies and phytochemicals* (2019): 179-201. <https://doi.org/10.1201/9780429057892-15>
- [35] Chew, Kit Wayne, Shir Reen Chia, Pau Loke Show, Yee Jiun Yap, Tau Chuan Ling, and Jo-Shu Chang. "Effects of water culture medium, cultivation systems and growth modes for microalgae cultivation: A review." *Journal of the Taiwan Institute of Chemical Engineers* 91 (2018): 332-344. <https://doi.org/10.1016/j.jtice.2018.05.039>
- [36] El-Mansi, E. M. T., Jens Nielsen, David Mousdale, and Ross P. Carlson, eds. *Fermentation microbiology and biotechnology*. CRC press, 2018. <https://doi.org/10.1201/9780429506987>

- [37] Tan, Chung Hong, Chun-Yen Chen, Pau Loke Show, Tau Chuan Ling, Hon Loong Lam, Duu-Jong Lee, and Jo-Shu Chang. "Strategies for enhancing lipid production from indigenous microalgae isolates." *Journal of the Taiwan Institute of Chemical Engineers* 63 (2016): 189-194. <https://doi.org/10.1016/j.itice.2016.02.034>
- [38] Pavithra, Kirubanandam Grace, P. Senthil Kumar, V. Jaikumar, Kilaru Harsha Vardhan, and PanneerSelvam SundarRajan. "Microalgae for biofuel production and removal of heavy metals: a review." *Environmental Chemistry Letters* 18, no. 6 (2020): 1905-1923. <https://doi.org/10.1007/s10311-020-01046-1>
- [39] Klinthong, Worasaung, Yi-Hung Yang, Chih-Hung Huang, and Chung-Sung Tan. "A review: microalgae and their applications in CO<sub>2</sub> capture and renewable energy." *Aerosol and Air Quality Research* 15, no. 2 (2015): 712-742. <https://doi.org/10.4209/aaqr.2014.11.0299>
- [40] Gonçalves, Ana L., Filipe Almeida, Fernando A. Rocha, and António Ferreira. "Improving CO<sub>2</sub> mass transfer in microalgal cultures using an oscillatory flow reactor with smooth periodic constrictions." *Journal of Environmental Chemical Engineering* 9, no. 6 (2021): 106505. <https://doi.org/10.1016/j.jece.2021.106505>
- [41] Nguyen, Quyen, Iman Behroyan, Mashallah Rezakazemi, and Saeed Shirazian. "Fluid velocity prediction inside bubble column reactor using ANFIS algorithm based on CFD input data." *Arabian Journal for Science and Engineering* 45, no. 9 (2020): 7487-7498. <https://doi.org/10.1007/s13369-020-04611-6>
- [42] Jang, Nulee, Mungyu Lee, Muhammad Yasin, and In Seop Chang. "Behavior of CO<sub>2</sub>-water mass transfer coefficient in membrane sparger-integrated bubble column for synthesis gas fermentation." *Bioresource Technology* 311 (2020): 123594. <https://doi.org/10.1016/j.biortech.2020.123594>
- [43] Jafarian, Mehdi, Yusuf Chisti, and Graham J. Nathan. "Gas-lift circulation of a liquid between two inter-connected bubble columns." *Chemical Engineering Science* 218 (2020): 115574. <https://doi.org/10.1016/j.ces.2020.115574>
- [44] Zhang, Tao, Chaohai Wei, Chunhua Feng, Yuan Ren, Haizhen Wu, and Sergei Preis. "Advances in characteristics analysis, measurement methods and modelling of flow dynamics in airlift reactors." *Chemical Engineering and Processing-Process Intensification* 144 (2019): 107633. <https://doi.org/10.1016/j.cep.2019.107633>
- [45] Sirohi, Ranjna, Ashutosh Kumar Pandey, Panneerselvam Ranganathan, Shikhang Singh, Aswathy Udayan, Mukesh Kumar Awasthi, Anh Tuan Hoang, Chaitanya Reddy Chilakamarri, Sang Hyouon Kim, and Sang Jun Sim. "Design and applications of photobioreactors-A review." *Bioresource technology* (2022): 126858. <https://doi.org/10.1016/j.biortech.2022.126858>
- [46] De Vree, Jeroen H., Rouke Bosma, Marcel Janssen, Maria J. Barbosa, and René H. Wijffels. "Comparison of four outdoor pilot-scale photobioreactors." *Biotechnology for biofuels* 8, no. 1 (2015): 1-12. <https://doi.org/10.1186/s13068-015-0400-2>
- [47] Kilian, Oliver, Christina SE Benemann, Krishna K. Niyogi, and Bertrand Vick. "High-efficiency homologous recombination in the oil-producing alga *Nannochloropsis* sp." *Proceedings of the National Academy of Sciences* 108, no. 52 (2011): 21265-21269. <https://doi.org/10.1073/pnas.1105861108>
- [48] Fan, Fei, Zhongnan Fei, Minxi Wan, Jianke Huang, Weiliang Wang, Wenmin Bai, Maolei He, and Yuanguang Li. "The optimization of centrifugal pump driving horizontal tubular photobioreactor for enhancing astaxanthin production using heterotrophic *Haematococcus pluvialis*." *Journal of Biotechnology* 341 (2021): 168-174. <https://doi.org/10.1016/j.jbiotec.2021.09.017>
- [49] Yen, Hong-Wei, and Wei-Cheng Chiang. "Effects of mutual shading, pressurization and oxygen partial pressure on the autotrophical cultivation of *Scenedesmus obliquus*." *Journal of the Taiwan Institute of Chemical Engineers* 43, no. 6 (2012): 820-824. <https://doi.org/10.1016/j.itice.2012.06.002>
- [50] Qin, Chao, and Jing Wu. "Influence of successive and independent arrangement of Kenics mixer units on light/dark cycle and energy consumption in a tubular microalgae photobioreactor." *Algal Research* 37 (2019): 17-29. <https://doi.org/10.1016/j.algal.2018.09.020>